

**Vesta  
is at my  
place**



project#



**Vesta  
is at my  
place**

project# 

**Vesta  
is at my  
place**

project#



Project S  
Fin. 312

Trasformare oggetti di uso quotidiano in forme d'arredo che uniscano la praticità all'eleganza, colori e sfumature che rendono un progetto di design estremamente versatile: questo è il leitmotiv di **Project #4**, il sistema a rullo disegnato da **Fabrizio Cester**.

Esteticamente quasi impercettibile una volta chiusa, la tenda a rullo scompare completamente nel soffitto lasciando alla vista solo l'inconfondibile ed esclusivo design dai chiari riferimenti geometrici.

Transforming everyday objects into furnishings that combine practicality with elegance; colours and shades that make a design project exceptionally versatile: this is the theme of **Project #4**, the roller system designed by **Fabrizio Cester**.

Most unnoticeable once closed, the roller blind completely disappears into the ceiling, leaving only its unmistakable and exclusive design with clean geometric lines evident.



Fin. 51  
Bronzo Miami  
Miami bronze



Fin. A6  
Bronzo perlato  
Perlated bronze



Fin. A5  
Tortora perlato  
Perlated dove colored

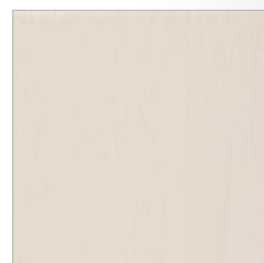

Fin. A3  
Beige

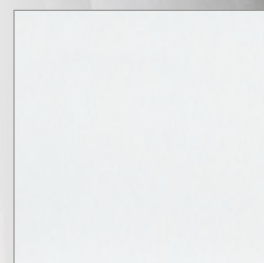

Fin. 312  
Bianco opaco  
Mat white



**Vesta  
is at my  
place**

project#



Project T  
Fin. 84

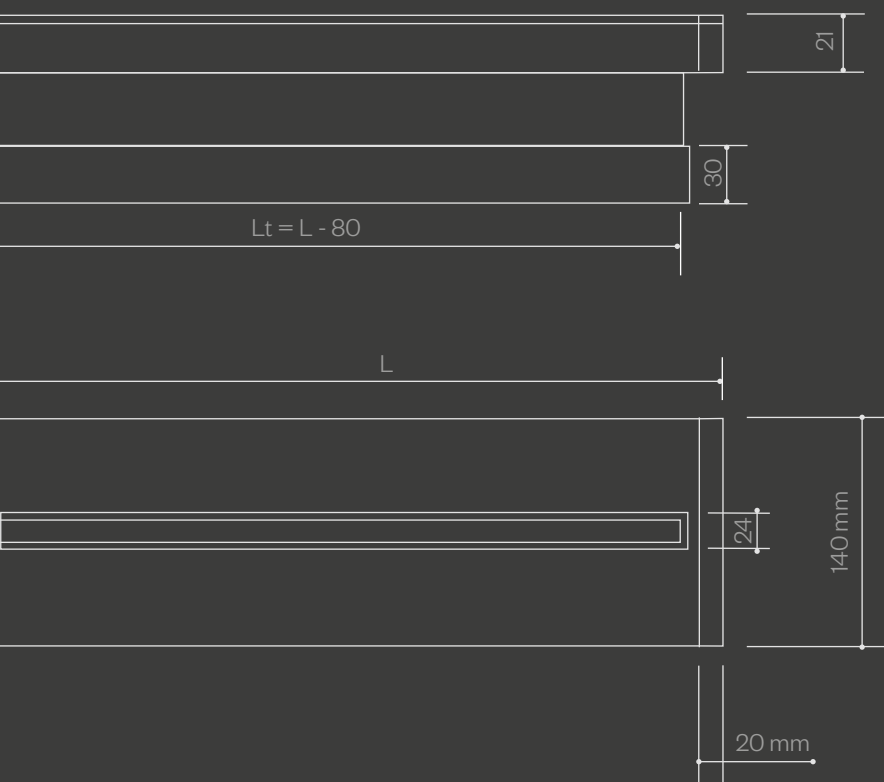

La capacità dell'azienda di adattare i prodotti in termini di forme, materiali e dimensioni agli spazi da arredare, ha portato anche in questo caso a soluzioni di arredo alternative che alternano l'ellitticità dei terminali ad una linearità geometrica più incisiva e funzionale.

The company's ability to adapt its products' shapes, materials and dimensions to spaces being furnished has also led to alternative solutions that alternate the oblong shape of the housing, with a more incisive and functional linearity.



Project T  
Fin. 84



**Vesta  
is at my  
place**

project#



Project S  
Fin. A6

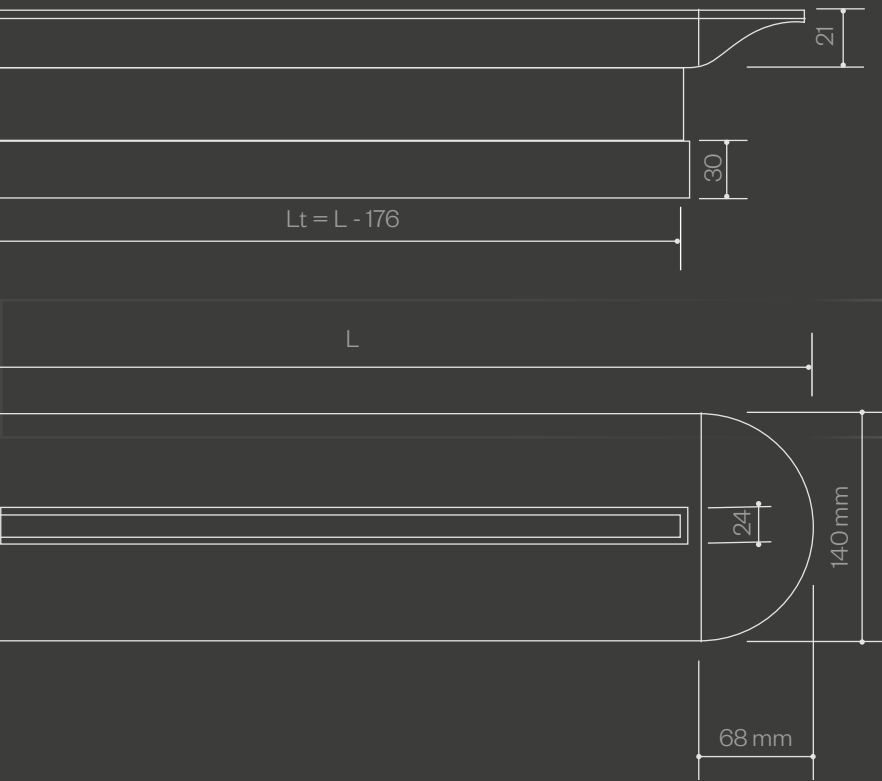

Project S  
Fin. A6





**Vesta  
is at my  
place**

project#

Vista in sezione e fissaggio cornice con molla  
Section view and pring frame fastening

Vista in sezione montaggio corpo e fissaggio con  
tasselli  
Structure mounting section view and plugs  
fastening

Montaggio sistema ad incasso  
Hidden system mounting

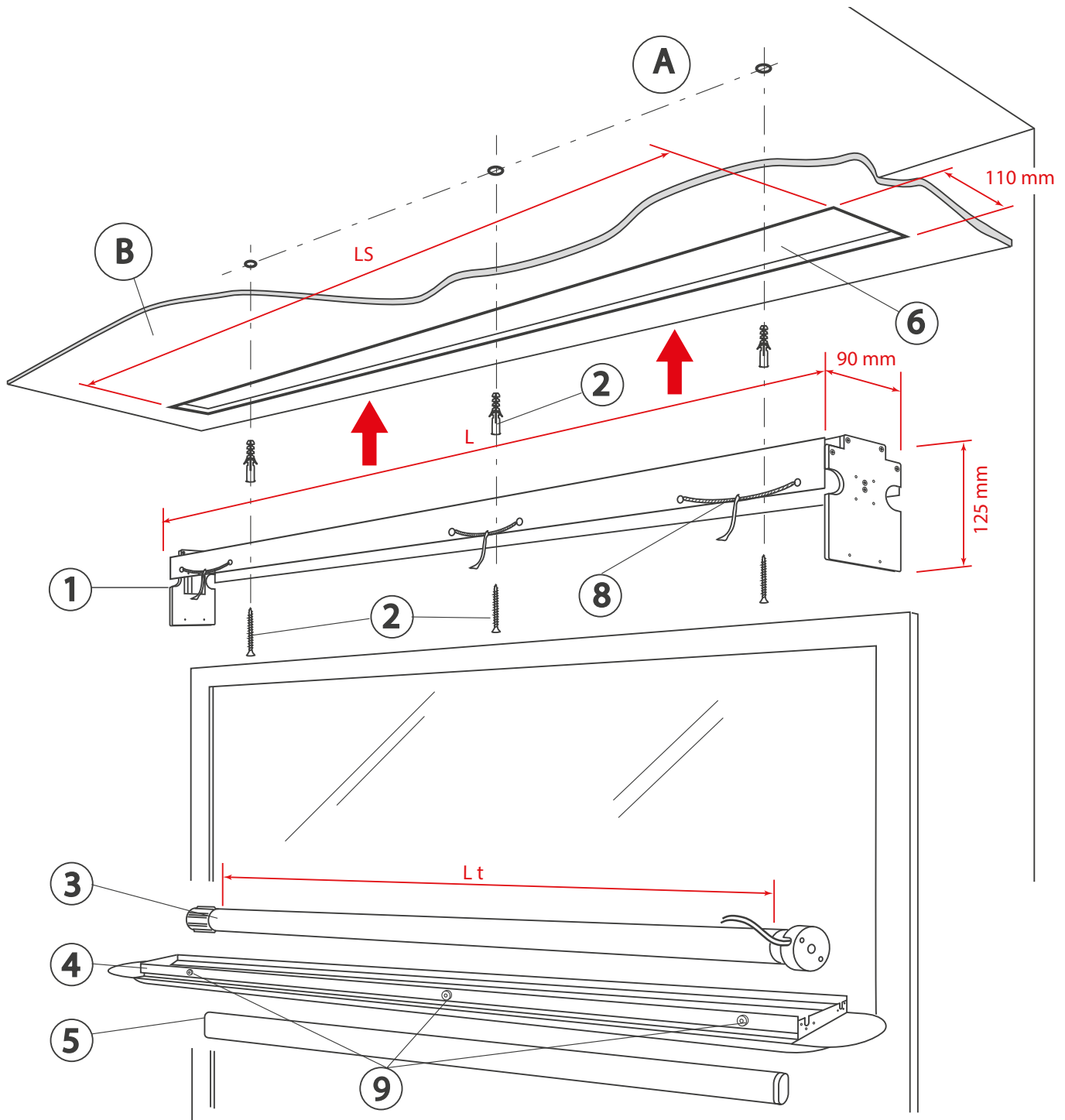

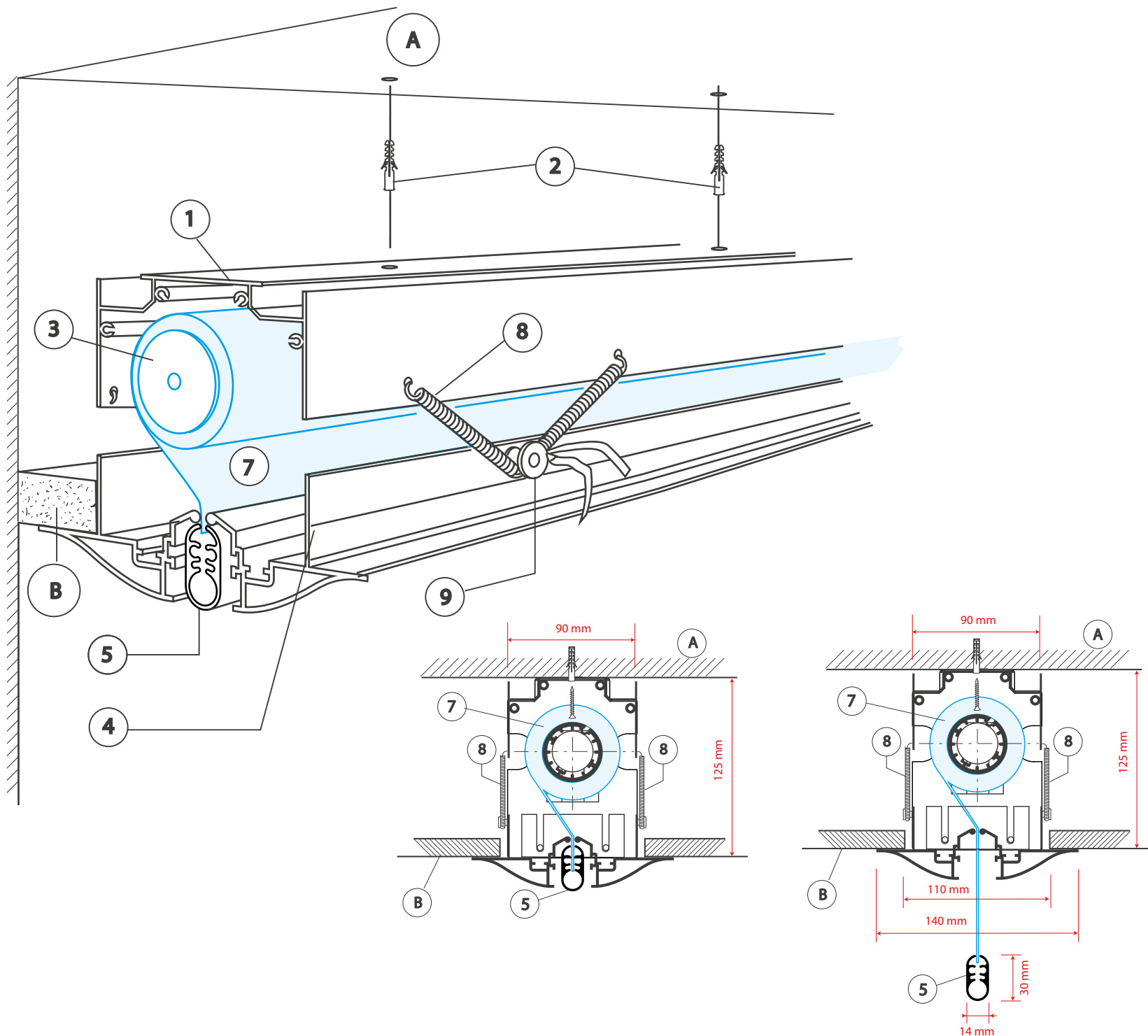

A.	Soffitto Ceiling	1.	Corpo Structure	6.	Foro controsoffitto Gypsum slot
B.	Controsoffitto False ceiling	2.	Viti e tasselli ad espansione Screws and wall plugs	7.	Tessuto Fabric
		3.	Rullo motorizzato Motorized roll	8.	Molla Spring
		4.	Assieme cornice esterna External frame	9.	Aggancio molla Spring fastening
		5.	Peso tenda / Chiusura sistema Bottom weight / System closing		

**Vesta  
is at my  
place**

4  
project#

**Project #4** significa ricercare geometrie essenziali e raffinate che si fondono per realizzare stili inediti pensati per valorizzare ambienti sia moderni che classici, consentendo innumerevoli combinazioni di colori e materiali, infinite possibilità creative che danno all'arredo un tocco particolare di eleganza.



Fin. 51  
Bronzo Miami  
Miami bronze



Fin. A5  
Tortora perlato  
Perlated dove colored



**Project #4** means essential and refined lines that blend to create new styles designed to enhance both modern and classic spaces. This allows for countless combinations of colours and materials and endless creative options, giving the furnishings a special touch of elegance.



Fin. 312  
Bianco opaco  
Mat white



Fin. A6  
Bronzo perlato  
Perlated bronze



**Vesta is at my place**

is a trademark of

**Casa Valentina** S.r.l.

via Ponte Gandovere 33  
25064 Gussago (Brescia)  
T +39 030 2410269  
casavalentina.it

design

**Cester Fabrizio**

graphic project

**Twins96** S.r.l.

print

**Color Art** S.p.a.

03/2020

**Vesta  
is at my  
place**

project# 

**Vesta  
is at my  
place**



project#